

CE

**bycool!**  
green line

**DINAMIC 1.1**

**24 V**



**Instrucciones de Montaje**

*Mounting Instructions*

**Instructions de Montage**

*Montageanweisungen*

**Istruzioni di Montaggio**

**ES** Spanish

**EN** English

**FR** French

**GE** German

**IT** Italian

## Assembly Recommendations

- Before starting assembly, please read instructions and follow them during installation process.
- Use the adequate tools for each operation.

## Electricity

- Disconnect ignition key.
- Disconnect battery before starting assembly.
- Make sure electric components are securely connected, checking their correct fitting.

## Warning

If, during assembly, the unit becomes slanted or the cabin drops with the unit mounted, wait for at least 60 minutes from the moment the unit is horizontal before starting up.

## Documentation included

Mounting instructions	220.AA1.1001
User's guide	220.AA1.1002
Troubleshooting	220.AA1.1003
Warranty	220.AA1.0010

Indications concerning position are:  
 RIGHT: Passenger side  
 LEFT: Driver side



Driving torques (N.m)			
Fillet	Steel Quality		Wrench opening
	8.8	10.9	
M6/100	10	13	10

Hoses assembly		
Driving torques (N.m)		
Hose size	Fitting Driving Torque	Tool
1/4"	13-15	Wrench 14mm.
3/8"	15-17	Wrench 19mm.







## Tools

- ..... Ratchet wrench of 10
- ..... Cruciform screwdriver TOP 10
- ..... Wrench of 10
- ..... Wrench of 11
- ..... Wrench of 14
- ..... Wrench of 17
- ..... Wrench of 19
- ..... Allen key of 6
- ..... Socket wrench of Ø10
- ..... Broach Ø 4
- ..... Drill
- ..... Broach Ø 6
- ..... Circular saw Ø 19
- ..... Circular saw Ø 22
- ..... Circular saw Ø 48
- ..... Scissors
- ..... Riveter M6

## Symbology

-  Fragile
-  Beware of cuts!
-  Electrical hazard

## Warnings

-  The installing personnel must have a sufficient training in vehicles air conditioning.
-  dirna Bergstrom, s.l. shall not be responsible for breakdowns or damages coming from an inadequate handling or installation of the equipment or from modifications and substitutions carried out without our express and written authorisation.
-  Amount of refrigerant gas load R-134a to be introduced in the circuit: 300 g.
-  Please see product warranty procedure included in Troubleshooting diagnosis.
-  Please see equipment User's Guide for its correct functioning of the remote control and control panel.
-  Once installation is finished, the following documents must be handed over to the user: User's Guide, Warranty and Troubleshooting Diagnosis.

**PRIOR OPERATIONS:**

- Disconnect the battery.
- Dismount the evaporation unit cover.



**1**

**CABIN INTERIOR:**

Introduce the template supplied and mark bores.

A- If there are 2 beds, place the template between the two.

B- If there is 1 bed, place the template on the bed.

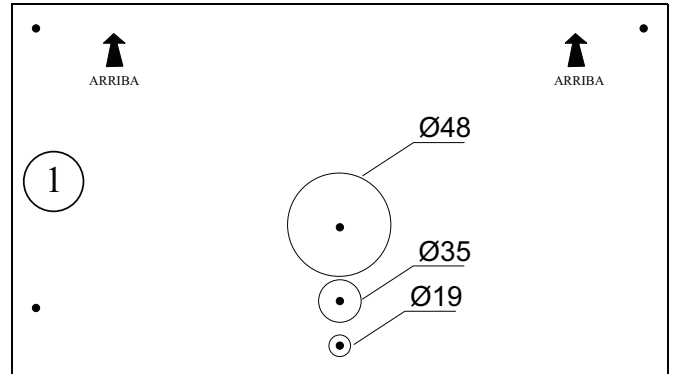

**2**

Make through bore Ø4 with long broach in bore position Ø48, and then make the following bores.

A- make (1) Ø35 in the cover only

B- make (1) Ø19 in the cover only

C- make (1) Ø48 in the cover only

D- make (4) Ø22 in the cover only

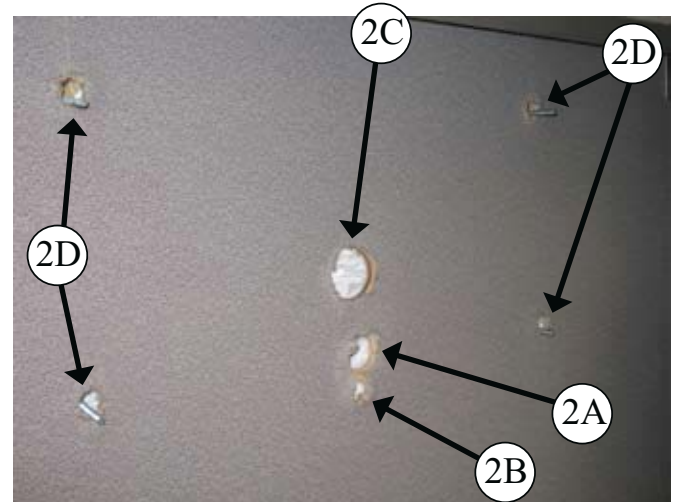
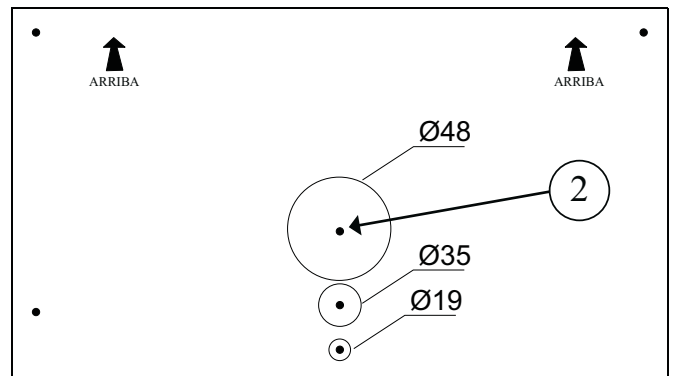
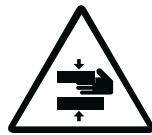

**3** **CABIN EXTERIOR:**  
 Introduce the template level using the exterior, taking as reference the Ø4 bore made, mark and make the remaining bores.

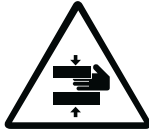
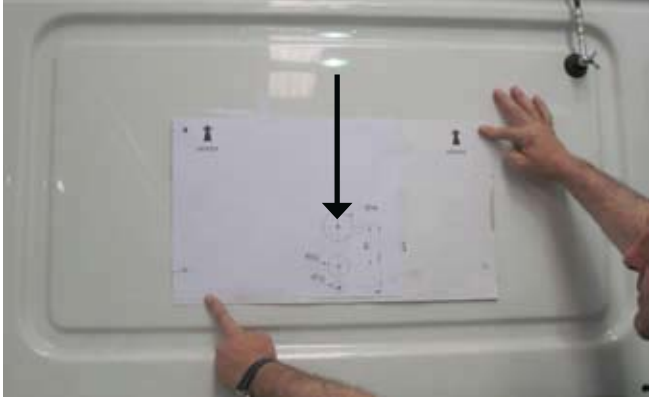

**4** Introduce M6 studs in the interior with a nut and washer as indicated.

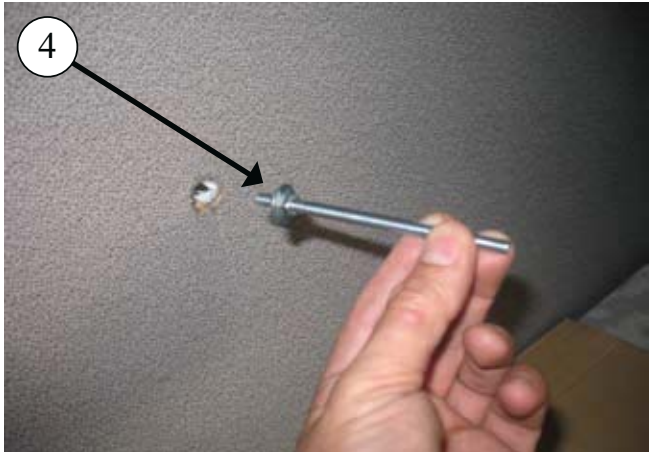

**5** Secure the exterior with a rubber washer, a flat washer and a self-locking nut, securing at the bottom with a socket wrench of 10.

**6** Position bushing and nut covers.

**7** Pass the waste water pipe through the bore of Ø19, through the bushing, towards the inside of the cabin.

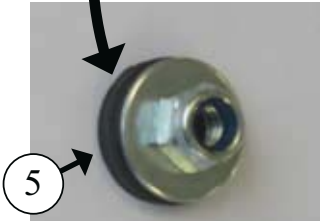
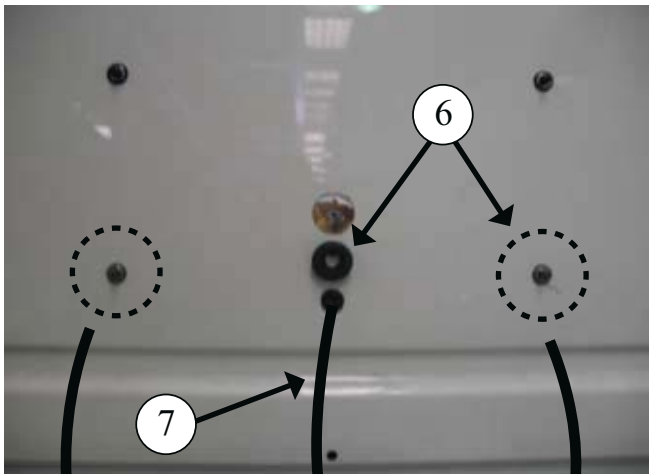

**OPERATIONS ONLY VALID FOR RENAULT MAGNUM MODELS**

**PRIOR OPERATIONS:**

- Disconnect the battery.
- Dismount the evaporation unit cover.

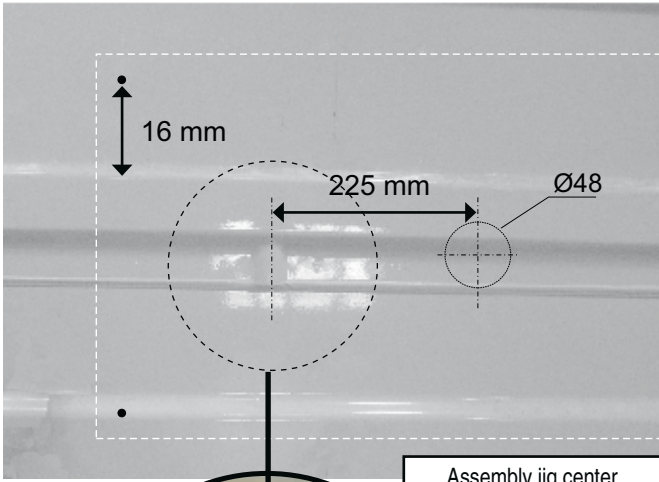

**1 CABIN EXTERIOR:**  
 Introduce the template supplied in accordance with levels.

**2** Mark all the bores.

**3** Make through bore Ø4 with long broach in bore position Ø48, and then make the following bores:  
 A- make (1) Ø19  
 B- make (1) Ø48  
 C- make (4) Ø7

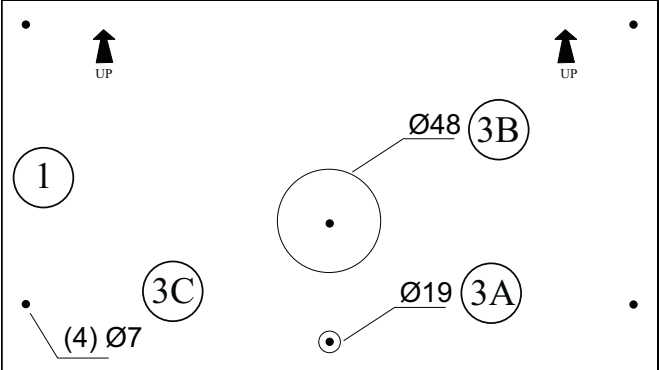
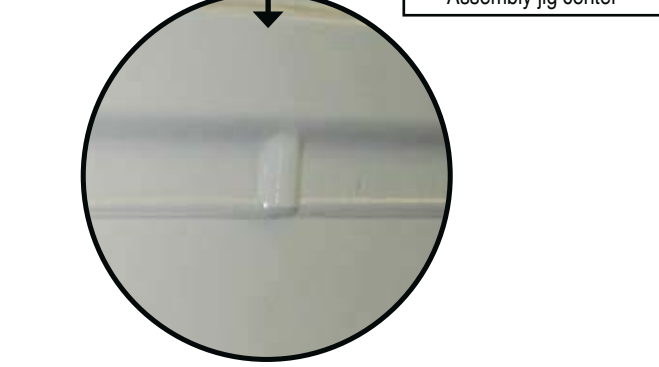

**4 CABIN INTERIOR:**  
 Introduce the template supplied and mark a bore of Ø48.

**5** Make the following bores:  
 B- make (1) Ø19 in the cover only  
 C- make (1) Ø48 in the cover only  
 E- make (4) Ø22 in the cover only

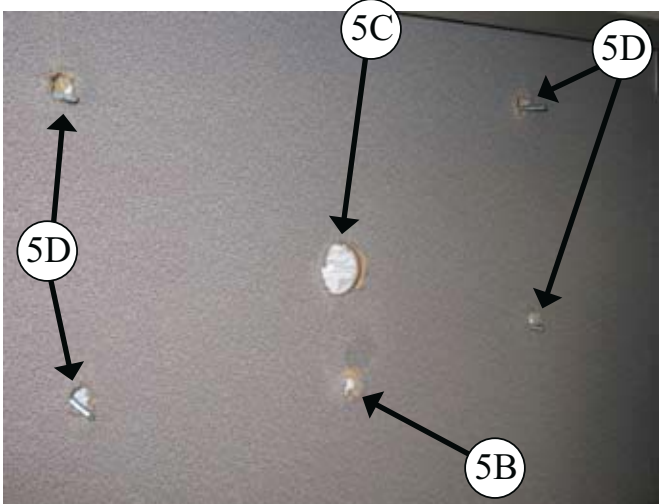

**OPERATIONS ONLY VALID FOR RENAULT MAGNUM MODELS**

**6** **CABIN EXTERIOR:**  
Introduce M6 studs in the interior with a nut and washer as indicated.

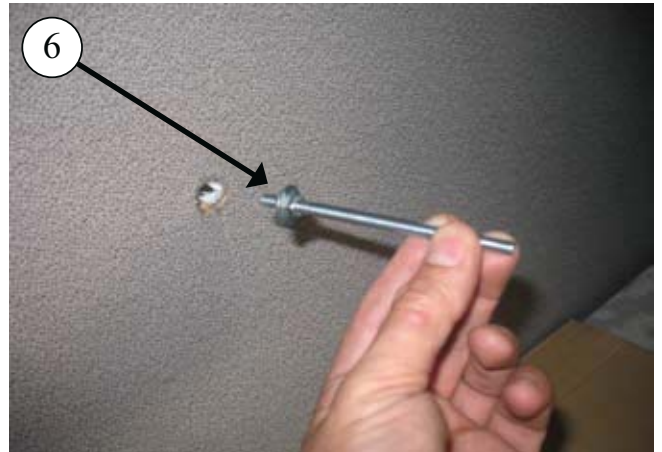

**7** Secure the exterior with a rubber washer, a flat washer and a self-locking nut, securing at the bottom with a socket wrench of 10.

**7A** Position bushing and nut covers.

**7B** Pass the waste water pipe through the bore of Ø19, through the bushing, towards the inside of the cabin.

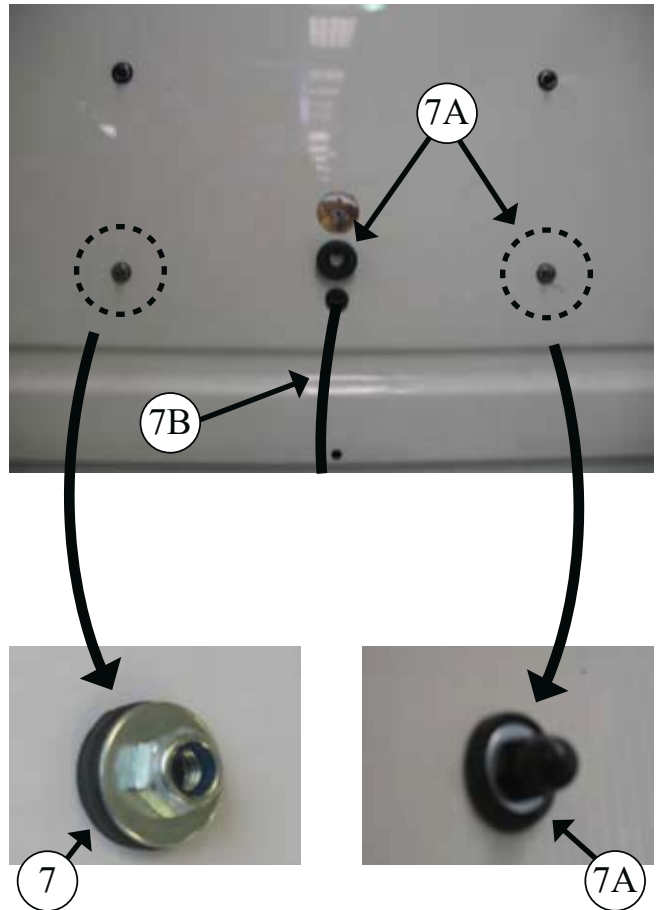



**OPERATIONS VALID FOR ALL MODELS**

**8** On the studs, thread (4) M6 nuts with (4) flat washers Ø 6, which should be level with the cover.  
**SEE ATTACHED DIAGRAM**

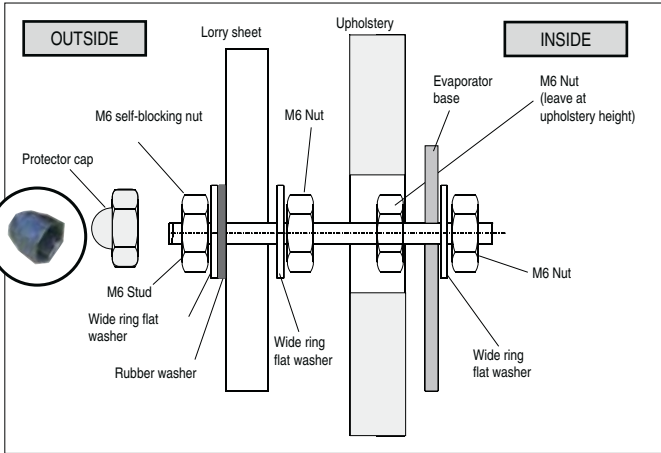

 **VERY IMPORTANT**  
 In the case of slanting upholstery, the evaporator unit must be vertical or sloping from the lower section to the outside in order to prevent the condensation water from dropping onto the upholstery.

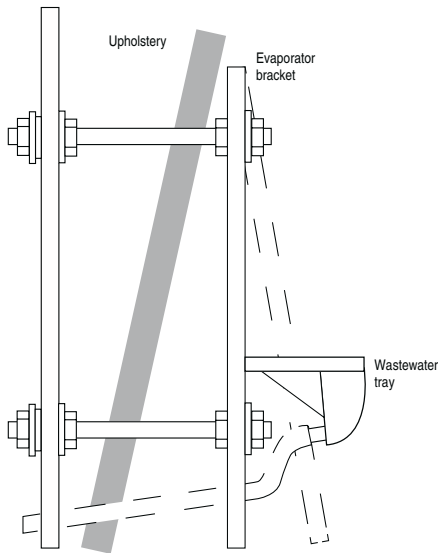

**9** Pass the waste water pipe through the bore of the evaporator base and connect to the tray.



**10** Pass the cabling through the Ø 35 bore towards the exterior.



**11** Introduce the evaporator base on the studs and secure with (4) flat washers, (4) Grower washers and (4) M6 nuts.



 **VERY IMPORTANT**  
The wastewater run-off must be sufficient to prevent water from dropping onto the upholstery.



**12** Connect recirculation probe and communications wiring.

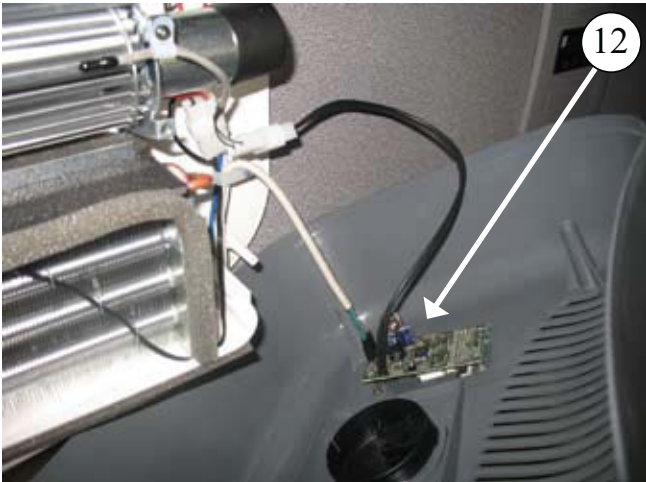



**13** Secure the front with its screws, using a magnetic screwdriver, and position the covers.



**CONDENSER ASSEMBLY:**

**Important:** Depending on the vehicle, we can position the pipe outputs on the right or left side.

**1** **Note:** When the installation is carried out by just one person, mark the bores with the indicated measurements, taking into account the pipe length (from the evaporator to the condenser).

**2** Dismount the cover and release the electro-cabling.

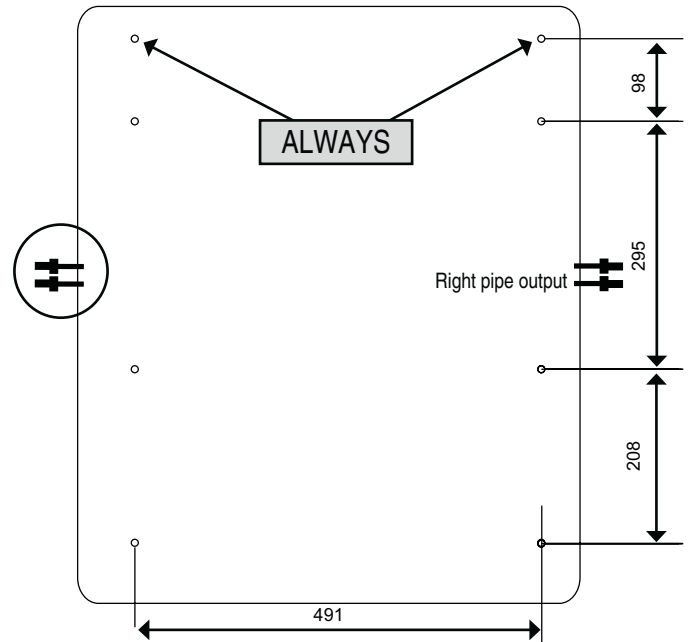

**3** **If this is carried out by 2 people,** introduce the capacitor base, placing it at the most appropriate part of the rear of the cabin, **taking into account the pipe length from the evaporator to the condenser,** and secure with at least 6 bores.

**4** First make the (2) upper bores (X) at  $\varnothing 9$ , position M6 rivet nuts and position the base with screws 6/100x30, mark and make the rest of the bores (Y), position the nuts.

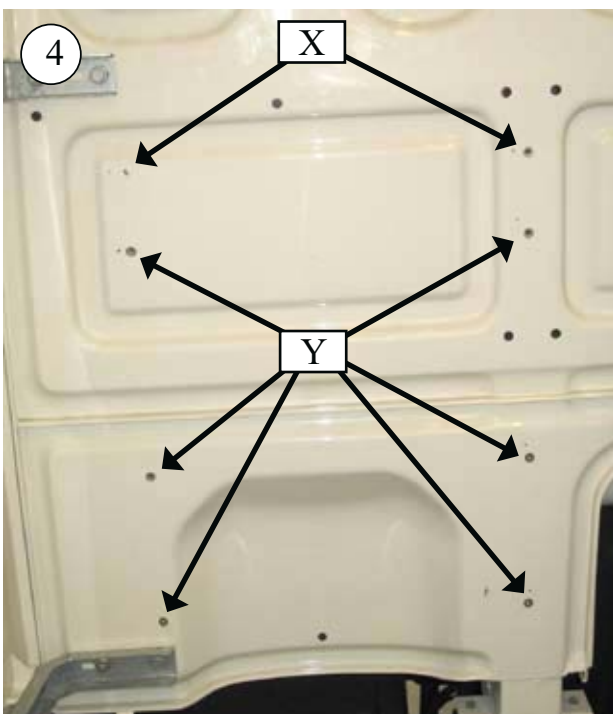

**5** Secure the unit with (8) 6/100X30 screws, grower washer and flat washer supported flat.



**5a** (\*)- When not supported on the smooth section, use a 10/20/40 mm separator and 6/100x40/60/70 screw.  
**SEE DETAILS A**

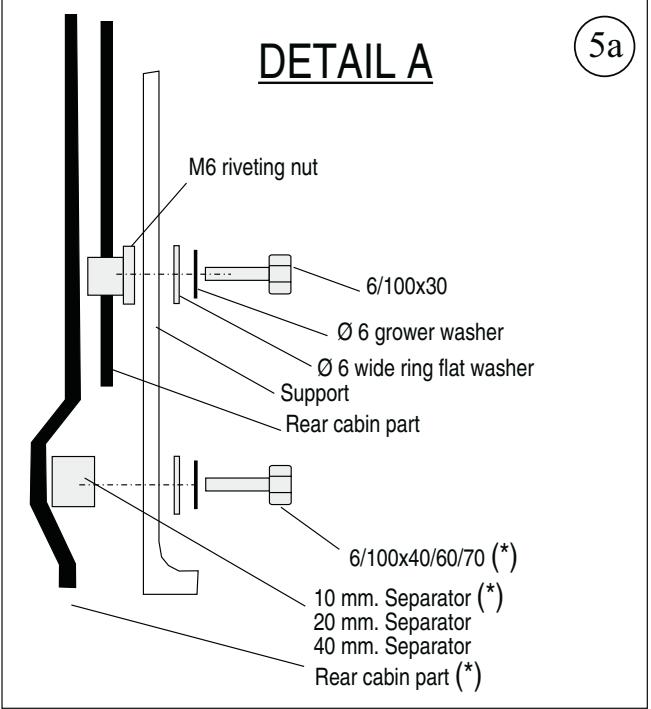

**6** Connect cabling and adapters in the evaporator and seal with drip-proof tape.

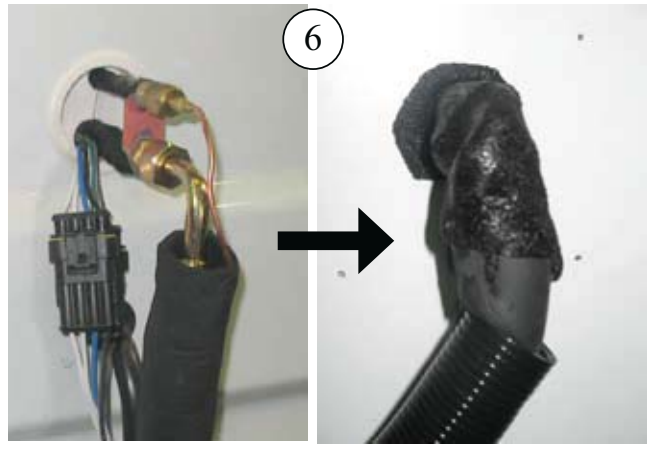

**7** Connect the pipes and cabling in the capacitor. If necessary use a 90° connection joint.

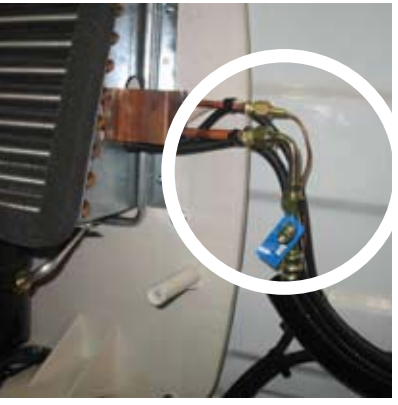

RIGHT SIDE

LEFT SIDE

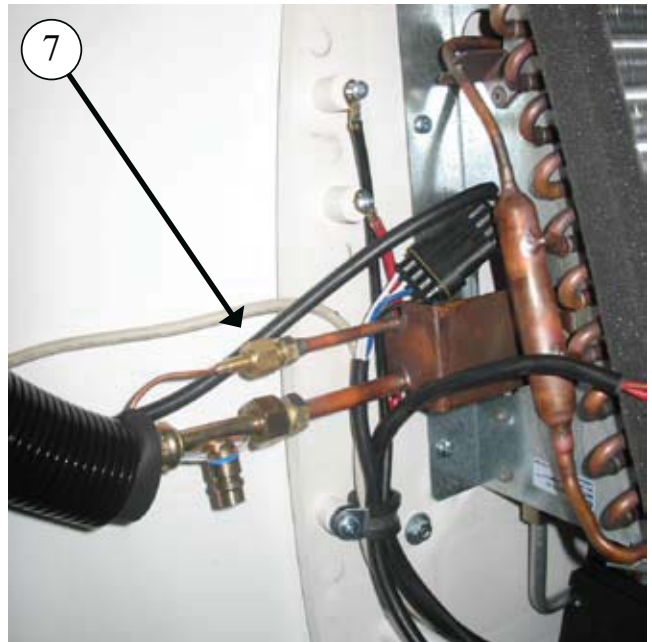

RIGHT SIDE





**8** Introduce pipe protector with flange, mark and bore at Ø4, and secure with threaded metal screws of 4.8x19mm.

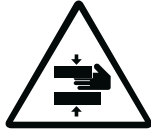

**9** Stick the plastic supports and secure the pipe, cabling and wastewater pipe (clean the assembly area).

**9A** Position drainage valve.

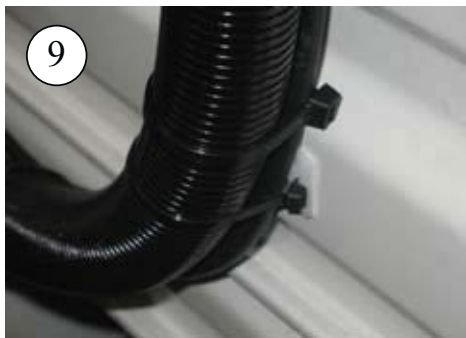



**10** Connect power cabling in battery.  
**TAKE CARE WITH POLARITY.**

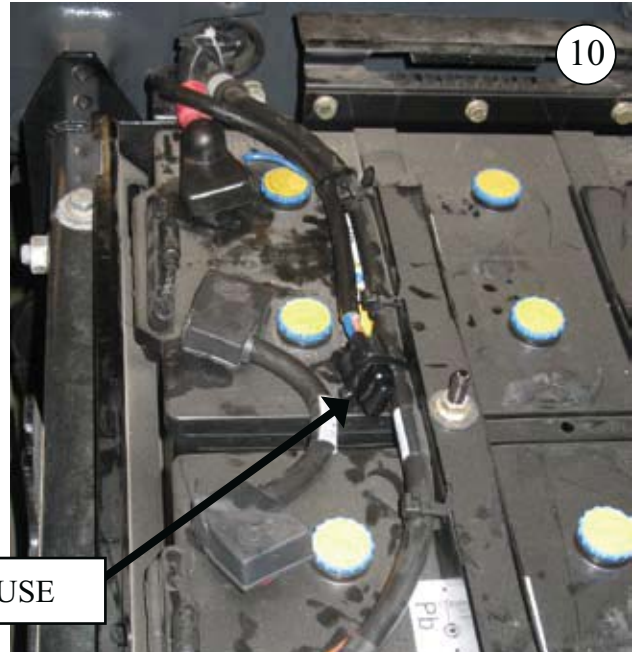
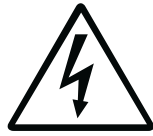

**Important:** Due to the complex system of electronic regulation of the equipment, the current connection must be made directly to the vehicle battery, and not to any other point which services other accessories of the vehicle, taking the precaution to not invert the polarity when making the connection (1). Inverting the polarity may result in irreparable damage to the electronics, which is not covered by the warranty.

**Important: Check the User Manual before starting up.**



**11** Open the cabin and pass the cabling through the most appropriate area towards the capacitor, securing with clamps or flanges.

**12** Connect the power cabling to the unit.  
 (-) = cables M and N.  
 (+) = cables R and Az.

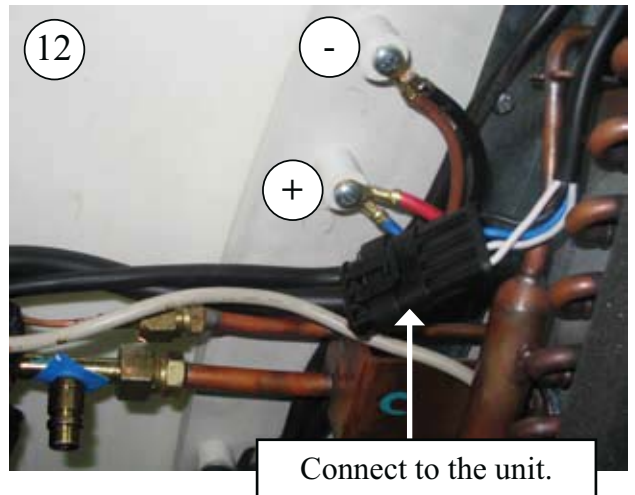

**13** Position the cover with the previously dismantled screws.

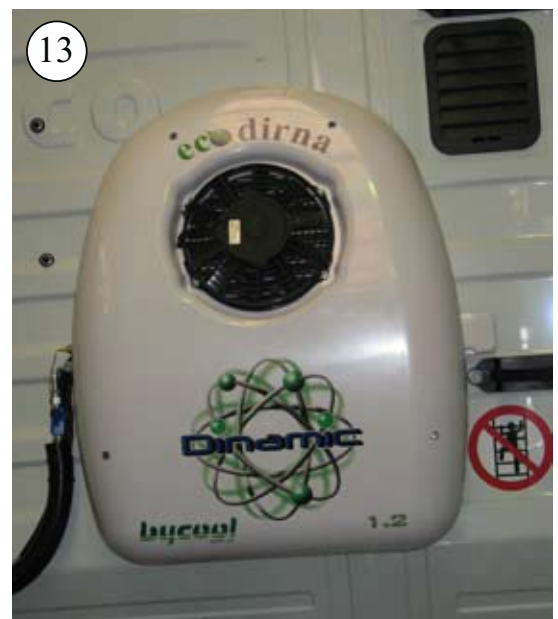

**14** Position adapter protection cover with metal threaded screws 3.1x 11 on the side opposite the pipes.



**GAS LOAD:**

**15** Empty the circuit for at least 30 minutes.

**16** Introduce 300 g of gas load R134a and start up the equipment.

**17** **GENERAL VIEW OF THE CONDENSATION UNIT AND PIPING.**



**18** **GENERAL VIEW OF THE EVAPORATION UNIT.**



# ELECTRIC WIRING

## IMPORTANT NOTE!

**Take care** not to invert the polarities when connecting the equipment to the battery. Should this occur, the electronic control will give out some beeps. **Do not touch any keys on the equipment switchboard or panel**, as this may produce irreparable damage. If you hear the beeps, disconnect the equipment from the battery and check the connection polarity.

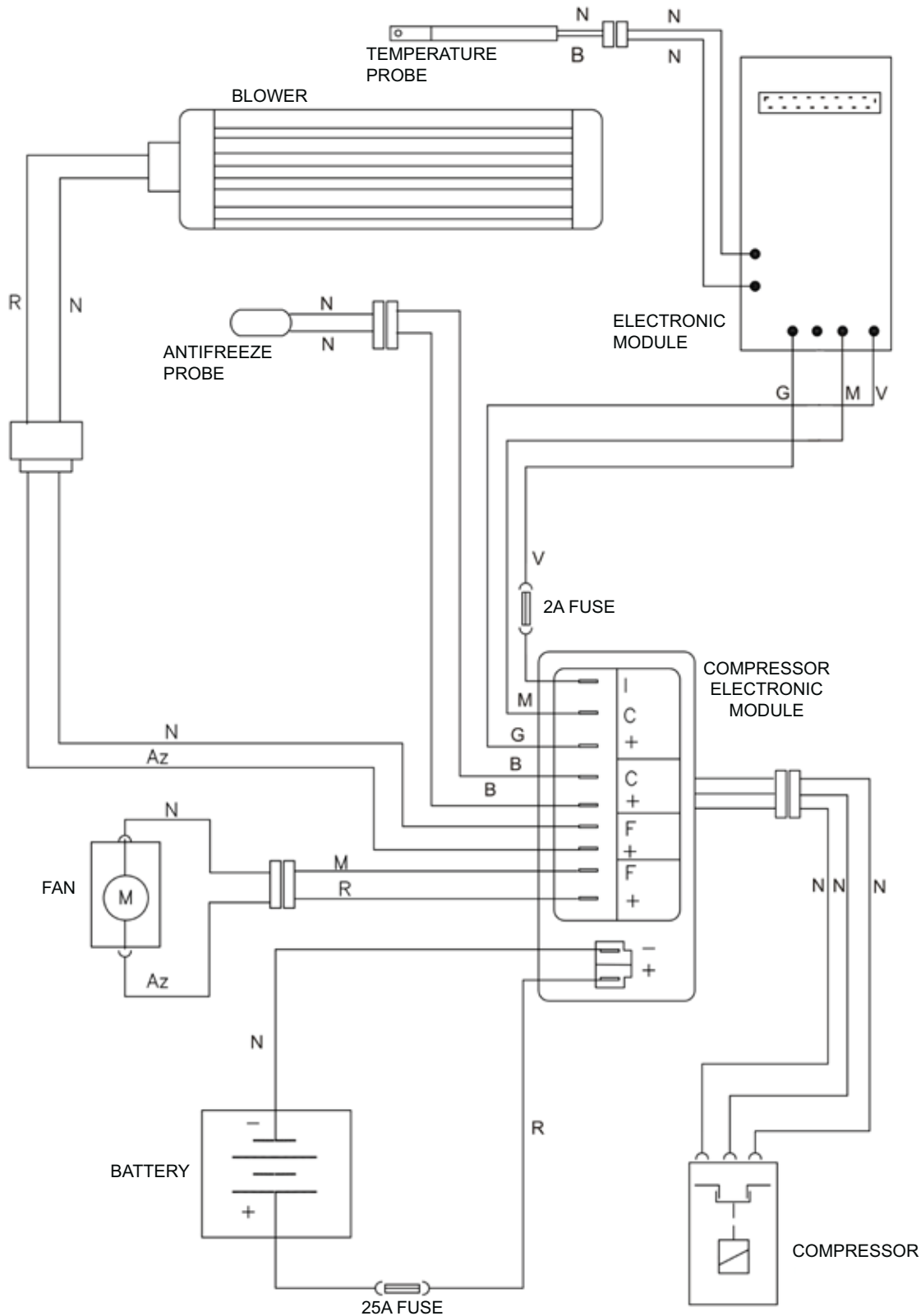

Az	Blue
N	Black
R	Red
V	Green
B	White
A	Yellow
Na	Orange
M	Brown

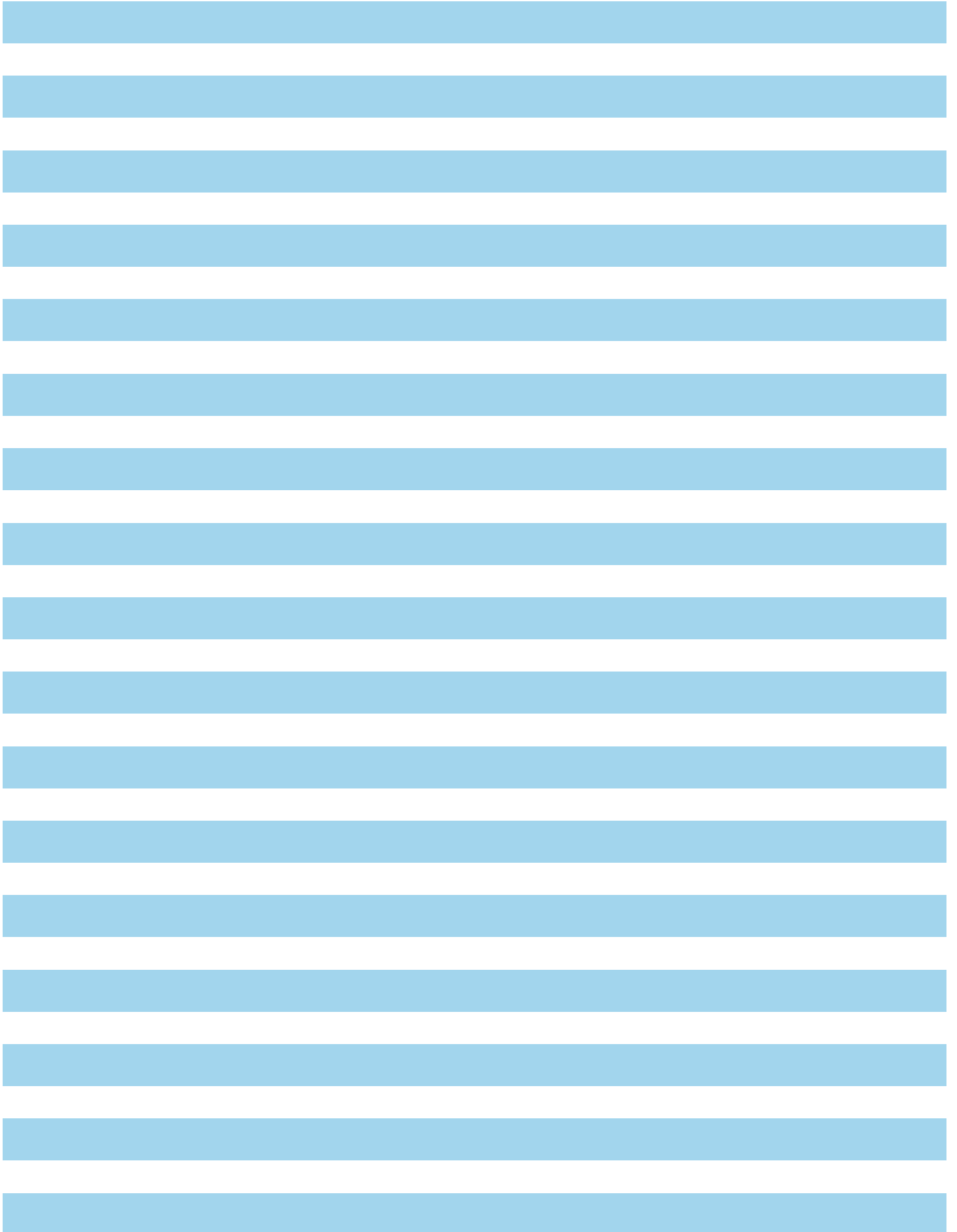



## Range of Products

**bycool!**  
 green line

**Air conditioning**



**COMPACT 1.4**



**COMPACT 1.6**



**COMPACT 2.0**



**COMPACT 3.0**



**bycool!**  
 blue line

**Evaporative Cooler**



**FLAT**



**REVOLUTION**



**CAMPER**



**MOCHILA**

Dirna Bergstrom es titular de todos los derechos de la presente información. La presente información es confidencial y queda prohibido cualquier acto de reproducción, distribución, comunicación pública y/o transformación de cualquier elemento de la misma sin la previa y expresa autorización de Dirna Bergstrom. Esta información ha de ser utilizada única y exclusivamente para el fin para el que fue creada, no siendo Dirna Bergstrom responsable de los posibles daños que se pudiera causar al cliente y/o a terceras partes por un incorrecto y/o inadecuado uso de la misma. Para cualquier aclaración al respecto pueden dirigirse al Centro de Comunicaciones del fabricante Dirna Bergstrom.

*DIRNA BERGSTROM is the holder of all the rights of this information. This information is confidential and it is absolutely forbidden any act of reproduction, distribution, public communication and/or transformation of any element of it without the previous and express authorization of DIRNA BERGSTROM. This information must be used only and exclusively for what it has been created, DIRNA BERGSTROM doesn't assume any responsibility of possible damages that could be caused to the client and/or third parties for a wrong and/or inadequate use of it. For any doubt about the aforementioned please contact DIRNA BERGSTROM by Communication Centre.*

Ed:	22/01/2010
Md:	25/04/2013



Francisco Alonso, 6  
28806 Alcalá de Henares, Madrid  
SPAIN

## CENTRO DE COMUNICACIONES COMMUNICATION CENTRE

### NACIONAL

**Centralita /Asistencia Técnica** ..... 918775841  
**Comercial** ..... 918775840  
**Fax** ..... 918836321  
**Email** ..... comercial@dirna.com

### INTERNATIONAL

**Tec. Assistance** ..... 0034 918775848  
**Fax** ..... 0034 918836514  
**Email:**..... export@dirna.com  
**Export Dept.** ..... 0034 918775846  
**Fax** ..... 0034 918771158

[www.dirna.com](http://www.dirna.com)  
[www.bycool.com](http://www.bycool.com)

	<b>ATENCIÓN:</b>	Dirna Bergstrom se reserva el derecho de efectuar modificaciones en cualquier momento de los datos contenidos en esta publicación, por razones técnicas o comerciales.
	<b>NOTE:</b>	<i>For technical and commercial reasons, Dirna Bergstrom reserves the right to change the data contained in this brochure.</i>
	<b>ATTENTION:</b>	Dirna Bergstrom se réserve le droit d'effectuer à tout moment des modifications des données reprises sur cette publication, pour des raisons techniques ou commerciales.
	<b>HIWEIS:</b>	<i>Dirna Bergstrom behält sich vor, aus technischen oder kaufmännischen Gründen jederzeit Änderungen der Angaben dieser Veröffentlichung vorzunehmen.</i>
	<b>ATTENZIONE:</b>	Dirna Bergstrom si riserva il diritto di effettuare modifiche in qualsiasi momento ai dati contenuti in questa pubblicazione, per motivi tecnici o commerciali.